

Reekie Machining Ltd

Insitu & Offsite
Machining Service



South Street
Inchinnan Business Park
Renfrew
Renfrewshire
Scotland
PA4 9RL

Tel: +44(0)141 812 0411 Fax: +44(0)141 812 0137
email: info@reekiemachining.co.uk
Web: www.reekiemachining.co.uk

R55 Data Sheet

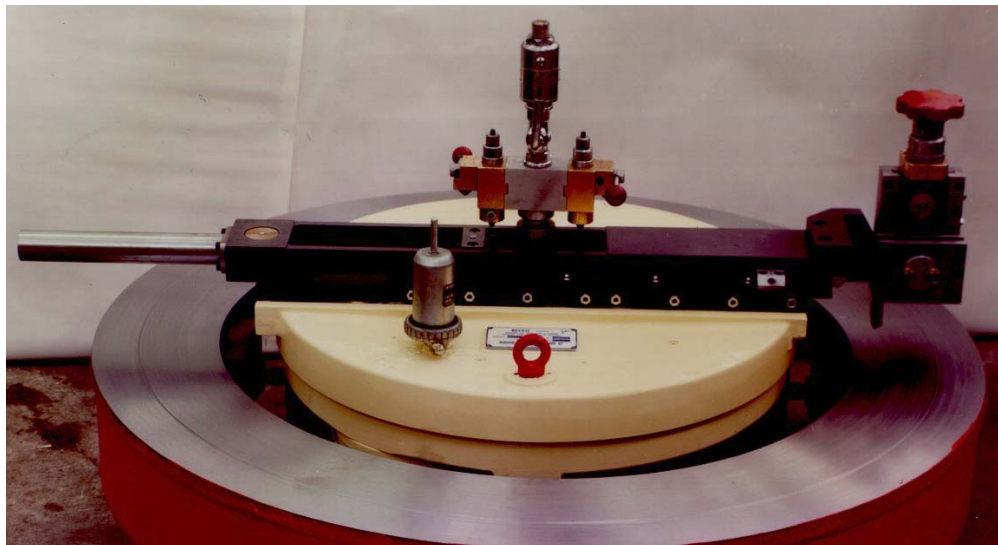

Portable Flange Facing, Boring & Grooving Machine

Minimum Location Dia: \varnothing 680mm

Maximum Turning Dia: \varnothing 1395mm

Automatic Radial Feed & Manual Vertical Feed

Air or Hydraulic Drive Motor Option

Grinding Attachment available

**Designed to operate in the horizontal, vertical, inverted
and inclined positions**

Reekie Machining Ltd

Insitu & Offsite
Machining Service



South Street
Inchinnan Business Park
Renfrew
Renfrewshire
Scotland
PA4 9RL

Tel: +44(0)141 812 0411 Fax: +44(0)141 812 0137
email: info@reekiemachining.co.uk
Web: www.reekiemachining.co.uk

R55 Specification

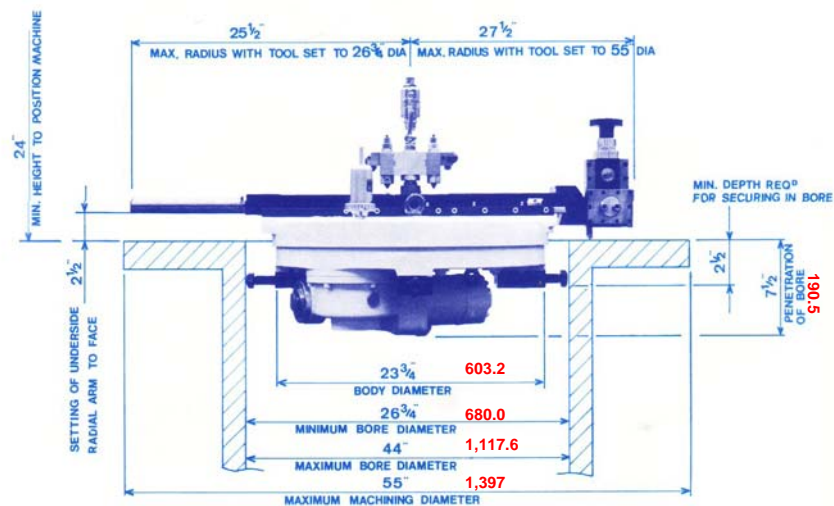

SHIPPING DATA

APPROXIMATE WEIGHT NETT	. . . 512 lbs.	232 kgs.
APPROXIMATE WEIGHT GROSS	. . . 728 lbs.	330 kgs.
CONTAINER DIMENSIONS	. . . 38 1/4" x 38 1/4" x 28 1/4"	980 mm, 970 mm, 730 mm.

All Machine Tool Permanent Wooden Containers are made to B.S.S. Packaging Code 1133

Reekie Machining Ltd have adopted a policy of continual improvement in their machines, the Designs and Specifications illustrated are therefore subject to change without notice and the Company reserves the right to despatch machines to the latest design